



# UHF RFID Antenna Ant-RC12-455/455

**Application:**

- ★ Intelligent transport system
- ★ Intelligent parking management---automatic vehicle identification
- ★ Expressway management--- automatic identification of driving route, traffic flow, information collection and so on.
- ★ Logistics &warehouse management
- ★ Sports event application
- ★ Personnel, access control, goods, animal husbandary management.
- ★ Other applications: manufacturing, retail, national defense security, electricity, finance, tickets, medical equipment, school, attendance, dining, swimming pool management

**Features:**

- ★ Attractive, install and use conveniently
- ★ Fast read & write, high performance, Long read & write distance
- ★ IP67

**Order Description:**

- ★865-868MHz: Ant-RC12-455/455-EU
- ★902-928MHz: Ant-RC12-455/455-CA

**Available Accessories:**

Antenna cables(optional,customizable):

- Ant-CA-SMA.M/N.M-LMR2-1M
- Ant-CA-SMA.M/N.M-LMR2-5M
- Ant-CA-SMA.M/N.M-LMR2-15M
- Ant-CA-SMA.M/N.M-LMR4-5M
- Ant-CA-SMA.M/N.M-LMR4-15M

**Mounting sets(optional):**

Ant-MOT-RC12-455/455-P

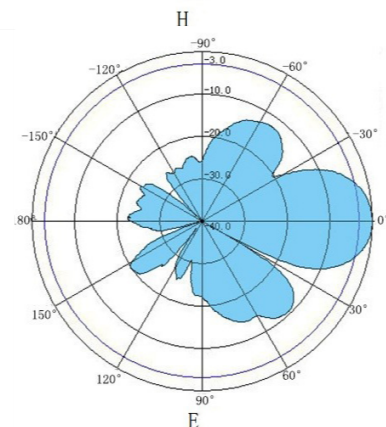
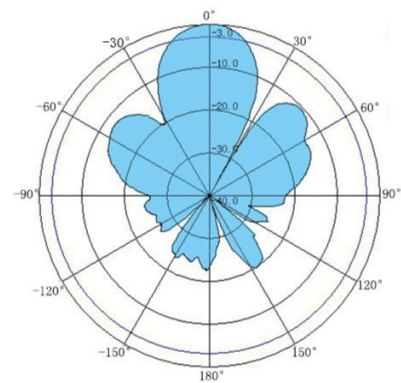

# Specification



Electrical	
Frequency Range	902-928MHz / 865-868MHz
Polarization Type	RHCP
Gain	12 dBi
3dB Beam-Width. H-Plan	40°
3dB Beam-Width. E-Plan	38°
VSWR	≤1.3
Front to back Ratio	≥17dB
Input Impedance	50Ω
Max Input Power	20W
Lightning Protection	DC Grounded

Mechanical	
Connector Type	N-Type Female
Dimensions H*W*D (mm)	445*445*30(mm)
Weight	2.66kg(with mounting bracket)
Radome Material	ABS
Radome color	Off-white
Radiant board material	aluminum
Operating Temperature	-40°C/+60°C
Sealing	IP67
Installation mode	Pole mounted
Support Pole Diameter	φ30-φ50(mm)
Rated Wind Velocity	60 m/s

## Installation diagram:

The antenna can be installed on the steel frame or pillar through its own bracket, and connected with the reader through the coaxial line. The antenna can be installed horizontally or vertically, depending on the installation orientation of the bracket. After installation, the tilt angle of antenna can be adjusted according to the actual situation to obtain the best performance of reading. The antenna can be used outdoors, but it is not suitable to use in acid-base environment.

1. Fix bracket to antenna with quarter US flange nut.

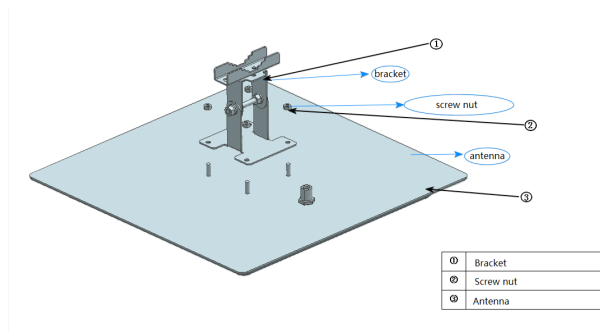

2. Fix the antenna on vertical steel frame or pillar with M8 \* 125mm screw, washer and screw nut.

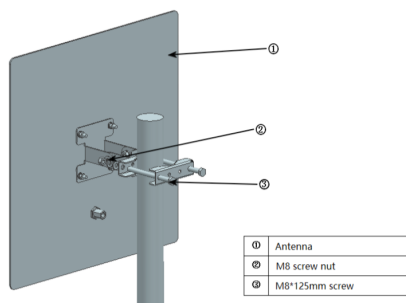

Notice: Product specifications are subject to change without prior notice. / Model: Ant-RC12-455/455 / Update Date: 2020-07-23

**CHAINWAY®**

Shenzhen Chainway Information Technology Co., Ltd

Address: 9F, Building2, Phase 2, Gaoxinqi Industrial Park, Liuxian 1st Rd., Bao'an District, Shenzhen, Guangdong 518102, China

Tel: 0086-755-23223316

Fax: 0086-755-23223310

Email: sales@chainway.cn

Web: <http://www.chainway.net>